



# "HC" SERIES BURNER SPECIFICATIONS

BURNER MODEL			HC-1	HC-34
CAPACITY, GPH <sup>1</sup>		MIN. MAX.	2.0 6.0	5.0 14.0
MOTOR HP RPM			1/6 1725	1/3 3450
FUEL UNIT	STANDARD	SUNDSTRAND WEBSTER	ONE STAGE	TWO STAGE
	OPTIONAL	SUNDSTRAND WEBSTER	TWO STAGE	
SOLENOID VALVE	STANDARD	H. OR EQUAL		YES
	OPTIONAL	H. OR EQUAL	YES	
TRANSFORMER			CONSTANT DUTY, 10,000 VOLTS	

<sup>1</sup> CAPACITIES ARE "UL" APPROVED. RATINGS MAY BE REDUCED UP TO 25% WHEN FITTED INTO CERTAIN BOILERS OR FURNACES.

NOTE - SPECIFICATIONS SUBJECT TO CHANGE WITHOUT NOTICE.

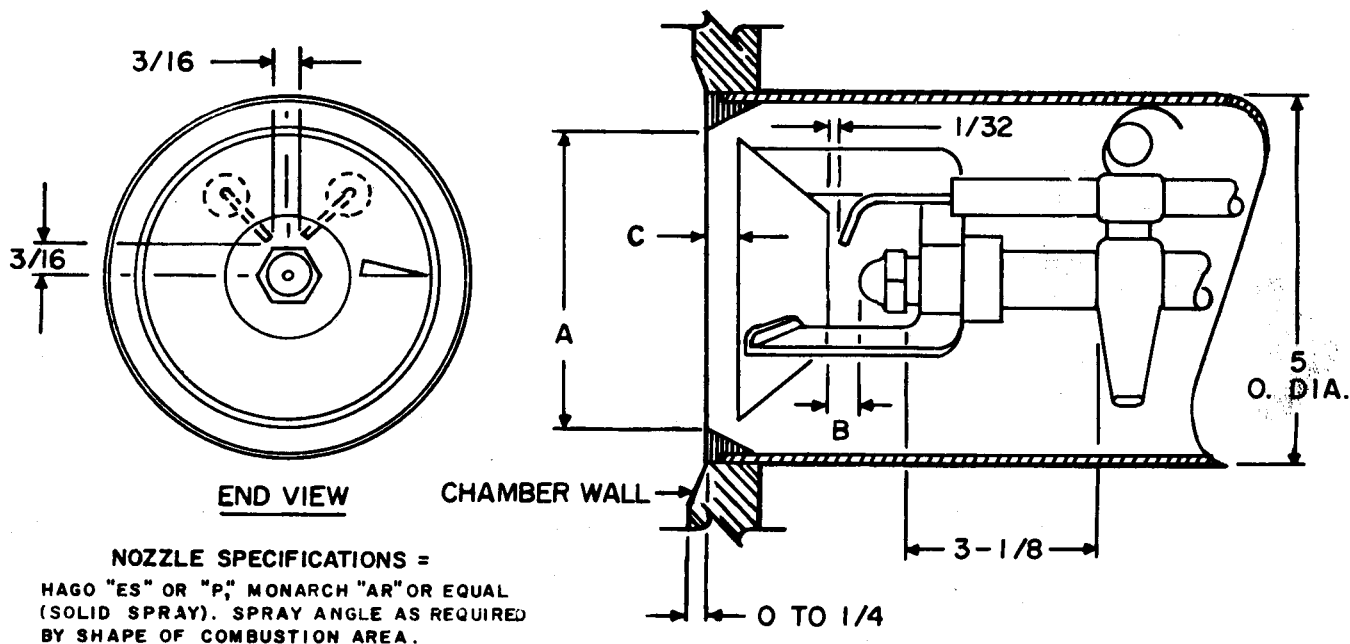

**NOZZLE SPECIFICATIONS =**  
HAGO "ES" OR "P," MONARCH "AR" OR EQUAL  
(SOLID SPRAY). SPRAY ANGLE AS REQUIRED  
BY SHAPE OF COMBUSTION AREA.

DIMENSION "A"

HC-1 = 4-1/2  
HC-34 = 5

DIMENSION "B"\*

30° 45° - 1/4    60° - 3/16

DIMENSION "C"

MIN. ADJUSTMENT    MAX.  
HC-1 = FLUSH    5/8  
HC-34 = 3/8    7/8

\* PART # H40071 SETTING GAUGE AVAILABLE ON REQUEST.

## FIRING ASSEMBLY — REMOVAL AND ADJUSTMENT

- To install the nozzle, the firing assembly must be removed: Remove copper tubing and screws holding back cover and slide plate. Disengage the buss bars; holding the buss bar and oil pipe, carefully pull out the firing assembly to prevent damage to the cup. NOTE: Spring pressure will cause some resistance. Do not force or bend the pipe and/or cup.
- Loosen clamp screw on cup bracket and remove from nozzle adaptor. Examine cup for distortion. A bent cup will alter the firing characteristics of the burner.
- Inspect the nozzle adaptor seat for any defects. A loose or improperly seated nozzle will cause an oil leak and poor oil cut-off. Use an "Ideal"-type nozzle wrench or two wrenches to remove or tighten the nozzle.
- Reinstall the cup on the nozzle adaptor with the leg having the part number centered between the electrodes. Set cup to dimension "B" and tighten clamp screw. Check that the cup bracket does not touch the electrode insulator.
- Set electrodes as shown (3/16" above nozzle centerline, 1/32" from cup and 1/8" or 3/16" gap, see diagram). NOTE: 1/32" setting remains constant regardless of nozzle spray angle in dimension "B."
- Reinstall firing assembly by reversing the procedure in paragraph 1.
- Cup to end cone dimension "C" should be within min. and max. adjustment. In shipping, assembly is locked in the min. or flush position. Index the assembly aft for maximum efficiency. When proper efficiency is obtained, slide adjustment lock to engage hex of the assembly; a fix setting will then be obtained.
- Tighten all screws and copper fittings.
- Check for leaks and oil cut-off before leaving premises.

# INSTALLATION INSTRUCTIONS

## #2 FUEL OIL BURNERS

### UNPACKING

When unpacking burner be sure all loose packages are inspected for contents. When burner is equipped with electronic controls, the relay is in a separate box packed with burner. Check packing list, voltage, cycles, and for concealed damage.

### TANK

1. All oil storage tanks must be U.L. approved and installed according to National Board of Fire Underwriters or local ordinances whichever has precedence.
2. All pipe connections on underground buried tanks must have swing joints except the sounding well (stick well).
3. The fill line must pitch toward tank  $\frac{1}{4}$ " per ft.
4. The vent line should not be less than  $1\frac{1}{4}$ " I.P.S. and equipped with an approved vent cap. Pitch toward tank  $\frac{1}{4}$ " per ft.
5. The tank gauge should be installed so that the float will not be under the fill line. On underground tanks protect bulb and gauge line inside tank with rigid iron pipe.

### OIL LINES

#### A. 275-Gal. Basement Tanks

1. Use  $\frac{1}{2}$ " O.D. copper tubing with flared fittings. Consult pump manufacturer specifications for other sizes and iron pipe substitution.
2. Install an approved hand valve in the tank outlet and close to burner pump before the filter. Connect from filter to pump with a copper tube pigtail. Do not connect rigid pipe directly to pump.
3. A return line is not required for this type installation.
4. If more than one burner is connected to suction line the tank bottom must be above both burner pumps and the size of line and filter must be increased.

#### B. Underground Or Vaulted Tanks

1. Use  $\frac{1}{2}$ " O.D. copper tubing with flared fittings for suction and return lines to avoid underground connections. If local regulations require rigid pipe, use black wrought iron and malleable fittings with double swing joints to prevent breakage in case the tank settles. (Consult pump manufacturer's specifications for other sizes and iron pipe substitutions.)
2. Both suction and return lines should extend to within 4" of the tank bottom.
3. Slip fittings should be used on the tank for copper suction and return lines. Double-tapped bushings can be used with wrought-iron pipe; however, a bushing welded to the dip tube is preferred.
4. Install, in suction line at outside wall, an approved hand valve and spring loaded ball check. When the tank is vaulted and the bottom of tank is on same level as burner, install a vertical check valve as close to top of tank as practical.
5. If bottom of tank is above the level of the burner, an anti-syphon valve is usually required at the highest point.

**In All Communications State Burner Model and Serial Numbers**

# **INSTALLATION INSTRUCTIONS**

## **#2 FUEL OIL BURNERS**

6. Install an approved hand valve close to burner pump, before the filter, and connect from filter to pump with a copper tube pigtail.
7. Install a copper tube pigtail between pump and spring-loaded ball check in return line.
8. Avoid fastening suction and return lines to floor beams. If necessary to do so, use loose fitting hangers with soft rubber lining to prevent noise transmission.
9. A separate suction line must be used for each burner. A common return line may be used, provided a spring-loaded ball check is installed in the return pipe from each fuel unit.

### **FILTER**

1. A filter is recommended in the suction line.
2. Size filter according to g.p.h. of nozzle on single pipe installations.
3. Use large filters on 2-pipe systems (20 to 30 g.h.p. rating).

### **BURNER SETTING**

1. Use base or flange mounting, whichever is most practical for the installation. Follow heating unit manufacturer's recommendations where applicable.
2. Level burner across the top.
3. Pitch draft tube down approximately 2° to 4° toward nozzle end.
4. End of draft tube should be 0" (flush) - ¼" from the inside of chamber wall. Improper insertion will distort fire.
5. Insulate around draft tube to prevent overheating of tube, nozzle and components. Make sure all cement is cleaned from inside of tube, drain hole in air cone and firing head. Pieces of insulation or cement in tube or head will distort the flame.

### **NOZZLES**

1. Use nozzle of the proper size, type and spray pattern as indicated for the model. (See inside front cover.)
2. Always remove nozzle assembly to install or replace nozzle.
3. Use an "IDEAL" nozzle wrench or two wrenches to tighten nozzle.
4. Nozzle must be tight to prevent an oil leak and after fire.

### **ADJUSTING NOZZLE ASSEMBLY**

1. Set nozzle and electrodes according to specifications (see inside front cover).
2. The electrode points must be set out of the spray, and the spark should contact oil mist.
3. Use flame mirror to check the setting.

### **CHIMNEY**

1. Follow the recommendations of the heating unit manufacturer.
2. Chimney should be above the surrounding objects, tile-lined, with no obstructions and be in a good state of repair.
3. The smoke pipe should be set flush with inside of tile, and cemented in place.
4. All cleanout doors should be sealed.

**In All Communications State Burner Model and Serial Numbers**

# INSTALLATION INSTRUCTIONS

## #2 FUEL OIL BURNERS

### DRAFT REGULATORS

1. The use of a draft regulator is recommended and should preferably be mounted in the smoke pipe.
2. Use draft gauge to adjust to proper opening. See "draft" below.
3. The above does not apply to pressurized fire box boilers.

### AIR FOR COMBUSTION

1. A separate fresh air inlet to the boiler room is required for proper combustion.
2. An opening of 1½ to 2 times the area of the smoke outlet is necessary.
3. If the opening is screened the area should be increased by as much as 50%.
4. Boiler room must be closed off from any area where exhaust fans are installed.

### COMBUSTION CHAMBERS

Does not apply to packaged units where the chamber is supplied.

1. Refer to chart for correct chamber dimensions.
2. Chambers may vary slightly but should maintain approximately the same square inches of floor area.

### WIRING

1. All wiring must comply with the National Electric Code and local ordinances.
2. Refer to diagram supplied with burner or controls.
3. Use 105°C thermoplastic wire — Do not use less than #14 AWG wire.
4. Do not fasten conduit or BX cable to hot surfaces.
5. Photocell wires must be thermoplastic and in separate conduit.

### STARTING BURNER

1. Be sure boiler and oil tank are filled, all valves open and controls set for operation.
2. Open air adjustment partially, open fire door and turn on switch.
3. Prime pump according to manufacturer's recommendations and check pressure.
4. If safety lockout occurs, reset after 1 to 2 minutes.
5. Do not run fuel unit dry for more than 5 minutes.
6. Prime pump with oil on long suction lines.
7. When fire is established make a temporary air adjustment to clear any smoke. Leave fire door open until combustion chamber is dry. When normal temperatures are reached adjust draft and air shutter for a clean fire.

### DRAFT

1. After boiler and chamber are up to normal operating temperature set draft to —.02" to —.03" W.C. **over the fire.** Use a draft gauge.

### FINAL CHECKOUT

1. Use smoke tester and set burner air adjustment for not more than #2 smoke (Shell Bacharach scale).
2. Recheck draft and take CO<sub>2</sub> readings over fire and in breeching.
3. If a large differential between CO<sub>2</sub> readings is noted, air leakage is the most common cause. Reseal unit.
4. Open fire door, turn off oil valve and check out safety timing of combustion control.
5. Check operation of limit controls and thermostat.
6. Check for oil leaks.

All installations should be reinspected after 1 to 2 weeks of normal operation.

In All Communications State Burner Model and Serial Numbers

**TABLE 3  
MINIMUM COMBUSTION AREA FOR CONVERSION**

FIRING RATE	NOT APPLICABLE FOR I/B/R OR S/B/I RATED BOILER/BURNER UNITS				RADIATION			
G.P.H.	LENGTH	WIDTH	HEIGHT	BOILER CROWN SHEET TO CENTER OF NOZZLE & FLOOR TO CENTER OF NOZZLE	FLOOR AREA SQ. IN.	STEAM SQ. IN.	WATER SQ. FT.	AIR BTU x 1000
.75	9"	9"	9"	6"	81"	300	480	84
1.00	10	9	9	7	90	400	640	112
1.25	11	10	10	7	110	500	800	140
1.35	11	11	11	7	121	540	864	151
1.50	12	11	11	7	132	600	960	168
1.65	13	12	12	7	156	660	1056	185
1.75	13	13	13	7	169	700	1120	196
2.00	15	13	13	7	195	800	1280	224
2.50	16	14	14	7	224	1000	1600	280
3.00	17	15	15	7½	255	1200	1920	336
3.50	20	15	15	7½	300	1400	2240	392
4.00	21	16	16	8	336	1600	2560	448
4.50	24	16	16	8	384	1800	2880	504
5.00	25	17	17	8½	425	2000	3200	560
5.50	27	17	17	8½	459	2200	3520	616
6.00	27	18	18	9	486	2400	3840	672
6.50	27	19	19	9½	513	2600	4160	728
7.00	29	19	19	9½	651	2800	4480	784
8.00	32	20	20	10	640	3200	5120	896
9.00	34	21	21	10½	714	3600	5760	1008
10.00	34	24	24	12	816	4000	6400	1120
12.00	35	26	26	13	910	4800	7680	1344
14.00	40	26	26	13	1040	5600	8960	1568

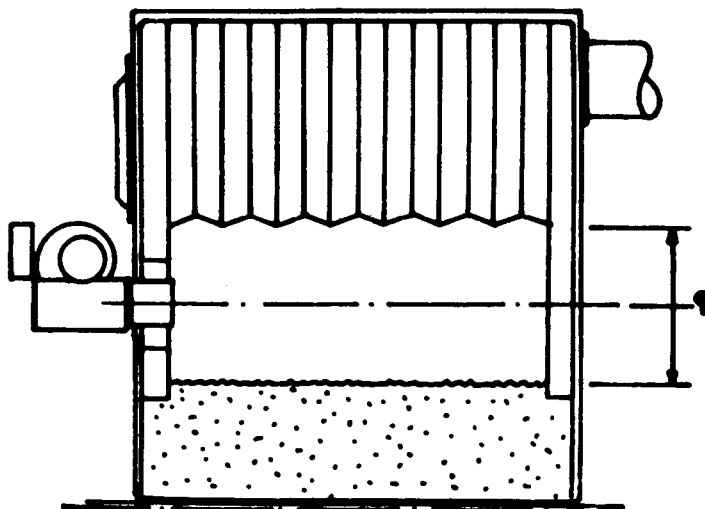
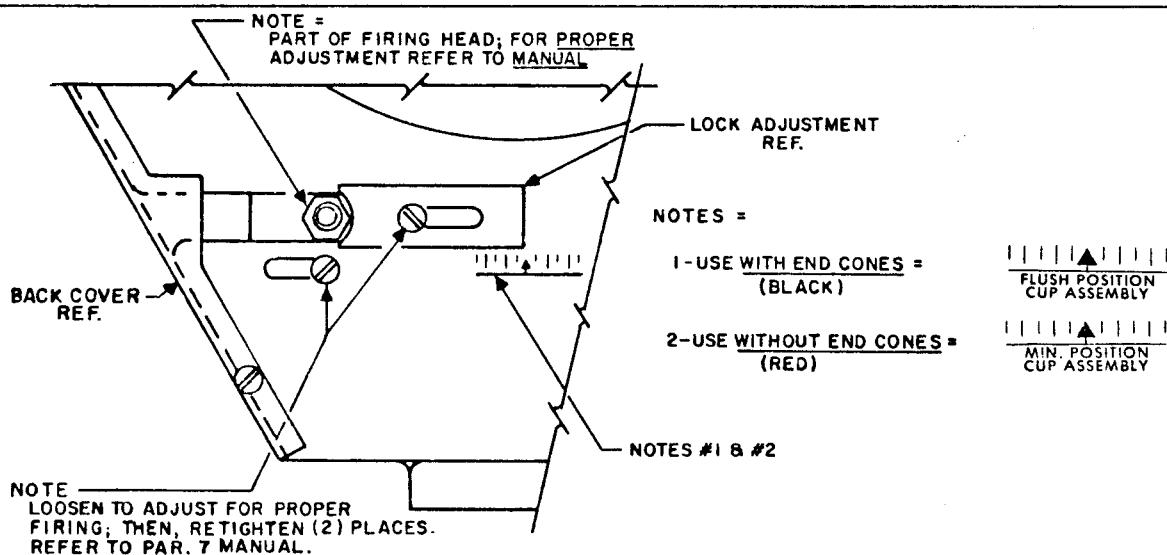

# "HC" GOLDEN CUP SERIES OIL BURNERS

## BURNER PARTS LIST

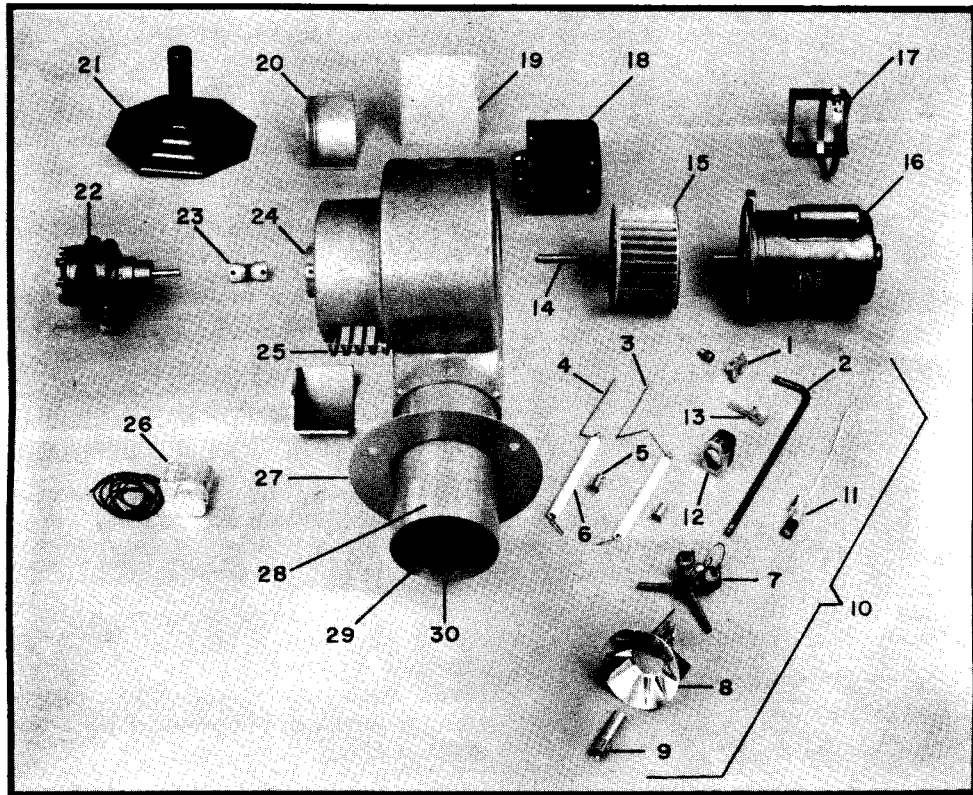

**ORDERING INFORMATION: STATE FULL MODEL NUMBER, SERIAL NUMBER, PART NUMBER, DRAFT TUBE LENGTH AND VOLTAGE.**

ITEM NO.	PART.NO	DESCRIPTION	HC-1	HC-34
1	C 41441	SLIDE PLATE	X	X
2	T 40211	NOZZLE OIL LINE (SPECIFY TUBE LENGTH)	X	X
3	E 40461	BUSS BAR, LEFT HAND (SPECIFY TUBE LENGTH)	X	X
4	E 40462	BUSS BAR, RIGHT HAND (SPECIFY TUBE LENGTH)	X	X
5	E 40041	ELECTRODE BUSHING (2 REQUIRED)	X	X
6	E 40351	IGNITION ELECTRODE (2 REQUIRED)	X	X
7	A 41191	ELECTRODE SUPPORT ASSEMBLY WITH SPRING	X	X
8	A 40711	GOLDEN CUP FLAME RETENTION, 3/4" O.D.	X	X
9	S 42352	NOZZLE ADAPTER	X	X
10	A 41171	FIRING ASSEMBLY (ITEMS 1-9 SPECIFY TUBE LENGTH)	X	X
11	E 41251	CAD CELL SENSOR (USE WITH HONEYWELL R8184 RELAY)	X	X
12	A 42191	PHOTOCELL DETECTOR (USE WITH HONEYWELL RA-890 - R-4150 OR WITH FIREYE TFC BURNER PRIMARY CONTROLS)	X	X
13	C 40531	PHOTOCELL PIPE MOUNTING BRACKET	X	X
14				
15	F 40221	BLOWER WHEEL, 6 1/4" DIA, X 4 1/4" HIGH X 1/2" BORE	X	X
16	M 40211	BURNER MOTOR - 1/6 HP, 115V, 60 CY, 1 PH, 1725 RPM	X	
	M 40431	BURNER MOTOR - 1/3 HP, 115V, 60 CY, 1 PH, 3450 RPM		X
17	S 41552	CONTROL MOUNTING BOX 4 x 4 x 1 1/2	X	X
	S 41131	CONTROL MOUNTING BOX STRAP ON BOX	X	X
18	M 40291	TRANSFORMER - 115 V, 60 CY, TO 10,000 V, MID-POINT GROUND	X	X
19	S 40611	FAN HOUSING BACK COVER	X	X
20	C 40551	ADJUSTABLE AIR SHUTTER (2 REQUIRED)	X	X
21	A 41521	PEDESTAL WITH NIPPLE (OPTIONAL)	X	X
22	P 40032	ONE-STAGE FUEL UNIT - 1725 RPM, 100 PSI, DIRECT DRIVE (SUNDSTRAND J3BA-200)	X	
	P 40075	TWO-STAGE FUEL UNIT - 3450 RPM, 100 PSI, DIRECT DRIVE (SUNDSTRAND H3PA-200)		X
23	R 40141	COUPLING, 6" LONG X 1/2" BORE X 3/16" BORE 2R	X	X
24	C 40351	FAN HOUSING	X	X
25	S 40861	AIR INLET GUARD	X	X
26	E 41151	SOLENOID VALVE - NORMALLY CLOSED, NON-DELAY, 150 PSI (SPECIFY MODEL)	X	X
27	A 42311	BURNER MOUNTING FLANGE WITH WEDGE (UNIVERSAL - OPTIONAL)	X	X
28	T 40091	AIR TUBE, 5" O.D. (SPECIFY TUBE LENGTH)	X	X
29	S 40701	STAINLESS STEEL TUBE COLLAR, 5" I.D. X 1 1/2" LONG		X
	C 40911	END CONE, 4 1/4" I.D. X 5" O.D.	X	
30	A 41201	AIR TUBE ASSEMBLY (ITEMS 28 AND 29, SPECIFY LENGTH)	X	
	A 41211	AIR TUBE ASSEMBLY (ITEMS 28 AND 29, SPECIFY LENGTH)		X

# OIL BURNER OPERATING INSTRUCTIONS

This Burner is listed by UNDERWRITERS' LABORATORIES, INC., and other agencies for fuel oil not heavier than No. 2 commercial standard CS-12-48.

## TO START BURNER:

(with main burner switch off)

1. Check oil level in storage tank.
2. Open all oil valves.
3. Check water level in boiler.
4. Check fuse or breaker.
5. Set thermostat above room temperature.
6. Open fire door and turn on main switch.

## TO STOP BURNER:

7. Turn off main switch.

## IF BURNER FAILS TO OPERATE:

8. Open fire door.
9. Recheck Items 1-6
10. Reset button on primary safety control.
11. Press manual reset on motor.
12. If burner still does not start, call service.

## STARTING BURNER AFTER FLAME FAILURE:

13. Open fire door.
14. Do not attempt to start if chamber is hot or if there are fumes or oil in chamber.
15. If Item 14 is satisfactory, reset primary safety control, BUT DO NOT RESET MORE THAN TWICE.

## TO STOP BURNER FOR PROLONGED PERIODS:

Turn off main switch, remove fuse, close oil line valves and fill oil tank to prevent condensation.

## MAINTENANCE:

Lubricate burner motor twice yearly with 4 drops of #10 S.A.E. motor oil. The complete heating system should be cleaned, adjusted and checked by a serviceman before the start of each heating season.

## INSTRUMENT READING DATA

Date \_\_\_\_\_

Stack CO<sub>2</sub>% \_\_\_\_\_

Air Shutter Setting \_\_\_\_\_

Stack Temp. F. \_\_\_\_\_

Net Stack Temp. F. \_\_\_\_\_

Overfire Draft H<sub>2</sub>O \_\_\_\_\_

Spray Angle ° \_\_\_\_\_

Chamber Size \_\_\_\_\_

Over fire CO<sub>2</sub>% \_\_\_\_\_

Smoke Spot No. \_\_\_\_\_

Room Temp. F. \_\_\_\_\_

Stack Draft H<sub>2</sub>O \_\_\_\_\_

Nozzle Installed gal./hr. \_\_\_\_\_

Boiler Mfg. \_\_\_\_\_

Combustion Efficiency \_\_\_\_\_

## WHEN SERVICE OR REPAIRS ARE REQUIRED

Call \_\_\_\_\_

Day telephone \_\_\_\_\_ Night telephone \_\_\_\_\_

Always give the following information:

Burner Model \_\_\_\_\_ Serial No. \_\_\_\_\_

Date installed \_\_\_\_\_

## CAUTION

DO NOT use gasoline, crankcase oil or any oil containing gasoline.

DO NOT incinerate garbage or refuse in this unit.

DO NOT tamper with burner or controls — CALL YOUR SERVICE MAN.

**HANG NEAR BURNER**