

## "DETROIT" No. 653 IMMERSION CONTROL

The No. 653 Immersion Control is specifically designed for use in domestic summer and winter hot water hook-ups and is of the low voltage type. The range adjustment is at the top of the case—see fig. 1. It is usually wired in parallel with the low voltage thermostat so as to operate the burner regardless of thermostat demands to maintain a constant boiler water temperature to provide domestic hot water.

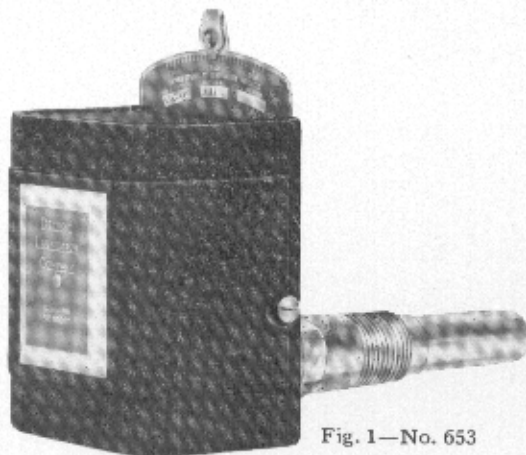

Fig. 1—No. 653

A durable bi-metal helix provides accurate operation and long, dependable service. The control is enclosed in a sturdy yet compact metal case, neatly finished in black wrinkle enamel.

The bi-metal helix is covered by a removable well threaded  $\frac{3}{4}$ " male N.P.T. The well is machined with an extended hub to provide the necessary clearance for jacketed boilers, and extends approximately  $2\frac{1}{8}$ " within the boiler. This separable well makes it possible to remove the control without the necessity of draining the boiler or tank.

The range plate and adjustment are on the outside of the case which makes it unnecessary to remove the cover when making the range adjustment. The range adjustment lever is supplied with a set screw so that the lever may be tightened, thus preventing accidental change in the setting. The differential adjustment is located within the case and is as illustrated in Fig. 3.

A permanent magnet of the "horseshoe" type insures a quick, snap action of the contacts. The control frame or case is of pressed steel—suitably reinforced to prevent distortion and change in control operating point.

Large screw terminals are used to simplify wiring and two insulated openings for the wires are provided in the bottom of the case.

Temperature Range:  $100^{\circ}$  to  $210^{\circ}$ .

Differential:  $10^{\circ}$  to  $25^{\circ}$ .

Immersion Well (see Fig. 2):  $\frac{3}{4}$ " N.P.T. connection.

Electrical Rating: 2 amps., 25 volts, 25 to 60 cycles.

Scale indicates temperature at which the circuit opens.

Circuit closes at range setting less the differential.

### Installation

The No. 653 Immersion Control may be installed in any position—in either top (vertical) or side (horizontal) boiler, tank or pipe line tappings. The well should be located so that it will be in contact with the average temperature of the liquid being controlled. Do not insert the well in the dead end of a pipe or boiler section or where it will come in contact with opposite side of the tapping. After the well has been installed, insert the bi-metal helix of the control in the well and tighten set screw "A"—Fig. 2.

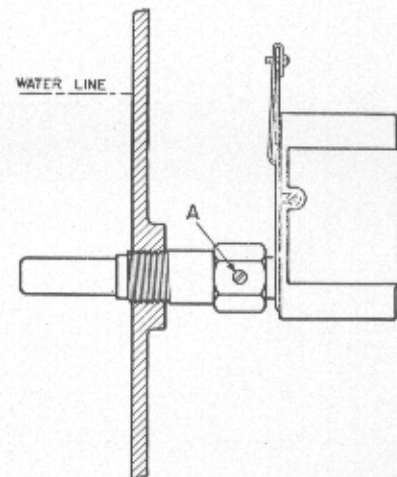

Fig. 2—Typical Application of No. 653

## Adjusting Instructions

The range adjusting lever and scale are at the top of the No. 653 Control. Loosen the set screw and move the lever to the temperature at which it is desired to have the control open the circuit. Making or changing this adjustment will not affect the differential.

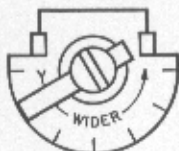

Fig. 3—Differential Adjustment

The differential adjustment, Fig. 3, is located inside the case near the magnet. The minimum differential is 10°—the maximum differential is 25°.

Should it be desired to check the calibration of this control, remove the control from the well and immerse the bi-metal coil in hot water, the temperature of which is known (approx. 150° F.). Close the switch by moving the range adjustment lever toward high end of dial until switch closes. Then slowly move the lever toward low end of dial until switch JUST opens. The indicator should now read 10° to 15° higher than the water temperature. This difference is to compensate for well loss and other variables covered under "Application".

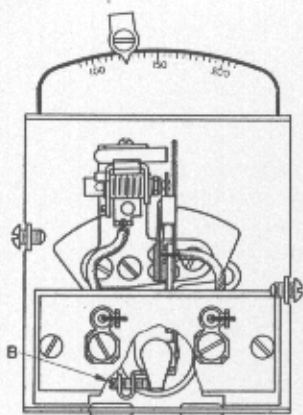

Fig. 4

If dial re-calibration is necessary turn calibrating screw "B" Fig. 4 to the right to increase the difference between bi-metal (water) temperature and dial reading, or to the left to reduce the difference between dial reading and bi-metal operating temperature. ONE TURN of calibrating screw changes dial reading approximately 16 DEGREES.

Keep water constantly at test temperature and the bi-metal in the water while making all tests and adjustments.

## Wiring Diagram

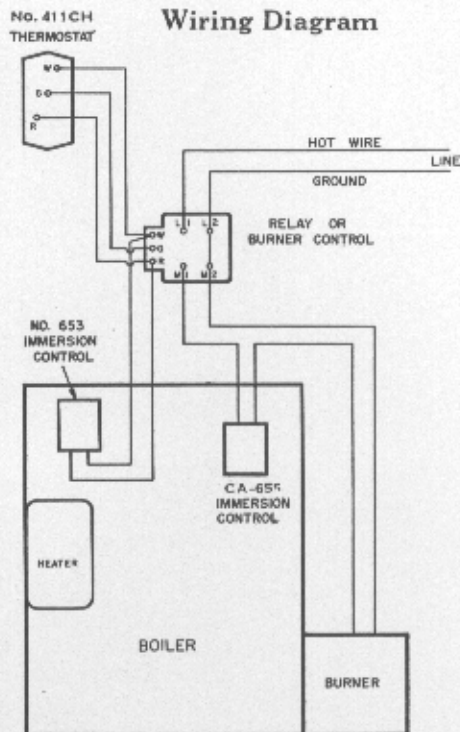

Fig. 5—No. 653 for Summer-Winter Hook-up and CA-655 as Limit Control on hot water heating system.

## Dimensions

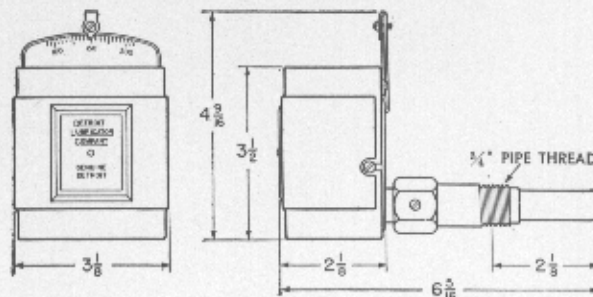

Fig. 6—Dimensions of No. 653

# DETROIT LUBRICATOR COMPANY

ESTABLISHED 1877

MAIN OFFICE AND FACTORY

5900 TRUMBULL AVENUE, DETROIT 8, MICHIGAN, U. S. A.

Division of **AMERICAN RADIATOR & Standard Sanitary** CORPORATION



NEW YORK, 18, N. Y., 40 WEST 40TH ST.  
GEO. E. CAGE, VICE PRESIDENT

REGIONAL SALES OFFICES  
REPRESENTATIVES

CHICAGO 5, ILL., 816 SO. MICHIGAN AVE.  
K. B. THORNDIKE, VICE PRESIDENT

ATLANTA, GA. - - - - -  
BOSTON 16, MASS. - - - - -  
CLEVELAND 15, OHIO - - - - -  
DALLAS 5, TEX. - - - - -  
DENVER 2, COLO. - - - - -  
DES MOINES 12, IOWA - - - - -  
KANSAS CITY 2, MO. - - - - -  
LOS ANGELES 13, CALIF. - - - - -  
MINNEAPOLIS 15, MINN. - - - - -  
PHILADELPHIA 6, PA. - - - - -  
ST. LOUIS 5, MO. - - - - -  
SALT LAKE CITY 1, UTAH - - - - -  
SEATTLE 4, WASH. - - - - -

1031 LANIER BLVD. - - - - -  
C/O A. R. & S. S. CORP., 441 STUART ST. - - - - -  
1900 EUCLID BLDG. - - - - -  
4401 STANFORD ST. - - - - -  
420 SECURITY LIFE BLDG. - - - - -  
6118 ROLLINS AVENUE - - - - -  
208 ALAMEDA RD. - - - - -  
320 CROCKER ST. - - - - -  
312 SO. THIRD ST. - - - - -  
535 CHESTNUT ST. - - - - -  
7041 NORTHMOOR DRIVE - - - - -  
153 W. SECOND ST., SO. - - - - -  
618 SECOND AVE., ROOM 816 - - - - -

W. A. EDWARDS - - - - -  
N. L. SELL - - - - -  
P. E. BOUCHER - - - - -  
W. D. KNOX - - - - -  
FRANKLIN SALES CO. - - - - -  
F. J. KREISSL - - - - -  
RIVARD SALES CO. - - - - -  
E. J. O'CONNELL - - - - -  
J. F. PAGE - - - - -  
R. L. STEPHENS - - - - -  
T. H. HART - - - - -  
CONELY ENGINEERING CO. - - - - -  
L. O. GRAUER - - - - -

CANADIAN REPRESENTATIVE—RAILWAY AND ENGINEERING SPECIALTIES, LIMITED, MONTREAL, TORONTO, WINNIPEG